



HATSAN
ARMS COMPANY

Serious. Solid. Impact.



PILEDRIVER

INSTRUCTION MANUAL

PLEASE READ THIS MANUAL BEFORE USING YOUR AIR GUN

Thank you for choosing the Hatsan PileDriver PCP air rifle.

Always use caution when operating this rifle. Learn and obey the laws of your local municipality, state, and/or country. Demonstrate responsibility while using this air rifle. **Please read this manual completely before handling or shooting your air gun.** It is the sole responsibility of the user to operate this air gun properly and safely.

Warning!

- Each Hatsan PCP air rifle contains pressurized air and should only be dismantled by a competent gunsmith. Do not attempt to dismantle the rifle if the rifle is partially or fully charged. Otherwise serious damage/injury/death may be caused to you or others. The air rifle may also become damaged. Never attempt to dismantle the air cylinder parts or air gauge when the air cylinder is fully or partially charged. Serious injury/death/damage may result if these instructions are ignored because pressurized air is in the air cylinder.
- Use only factory manufactured ammunition that fits the loading port of the rifle. Do not use steel or other hardened ammunition with your rifle.
- Hatsan PCP air rifles are designed specifically for use with dry compressed air. **NO OTHER GAS OR GAS COMBINATION CAN BE USED.**

The rifle may be filled from a diver's bottle or a suitable compressor, MAXIMUM SAFE WORKING PRESSURE (SWP) : 300 BAR (4,350 PSI).

GENERAL INSTRUCTIONS

Before using your new air rifle check that it is fully charged and abide by the following basic safety rules.

Basic Safety Rules:

- Treat every rifle as if it is loaded.
- Never point the rifle at anyone, or allow anyone to point a rifle at you, even if you know it is not loaded.
- Do not brandish or display this product in public – as it may confuse people and could be mistaken as a firearm.
- Always carry the rifle so that the direction of the muzzle is under control, even if you stumble.
- Always be sure of your target and what lies behind it before firing your rifle – this product may be dangerous up to 900 yards.
- Beware of targets that tend to cause ricochets.
- Never leave a loaded rifle unattended.
- It is compulsory that eye & ear protection is worn when charging the cylinder and when shooting.
- This is a high-powered airgun for use by those 16 years of age or older.

Section I. SPECIFICATIONS

The Hatsan PileDriver PCP rifle is a single-shot, manual loading air rifle with a non-removable 480cc volume air reservoir. Available calibers include .45cal and .50cal.

Model	Caliber	Muzzle Velocity(*)	Max Energy (*)		Max Energy Pellet Weight	Air Tube Volume	Fill Pressure
			Joules	Ft.Lbs			
PileDriver	.45cal	780 - 1100 FPS	950	700	520gr	480cc	300 BAR
	.50cal	720 - 1000 FPS	1095	805	700gr	480cc	300 BAR

* Velocity results may vary as much as 20% due to actual pellet weight, pellet size & shape, temperature, elevation, as well as other factors.

* The above maximum velocity figures are obtained under optimal conditions. Velocity will fall as the pressure in the air cylinder decreases.

Model	Caliber	Number of Shots at Optimal Velocity	Stock	Overall Length	Barrel Length	Weight
PileDriver	.45cal	4 - 6	Advanced Polymer Bullup w/ Adjustable Cheek & Butt	46.5"	33"	10lbs
	.50cal	3 - 5				

Section II. BASIC PARTS OF YOUR GUN

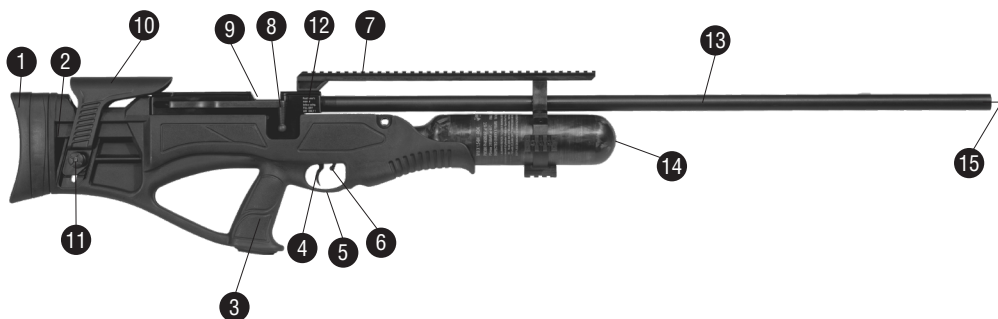

- | | | |
|------------------|-------------------|----------------------|
| 1. Butt Pad | 6. Safety Button | 11. Cheek Rest Screw |
| 2. Stock | 7. Scope Rail | 12. Receiver |
| 3. Grip | 8. Cocking Handle | 13. Barrel |
| 4. Trigger | 9. Loading Port | 14. Air Tube |
| 5. Trigger Guard | 10. Cheek Rest | 15. Muzzle |

Section III. MANUAL SAFETY

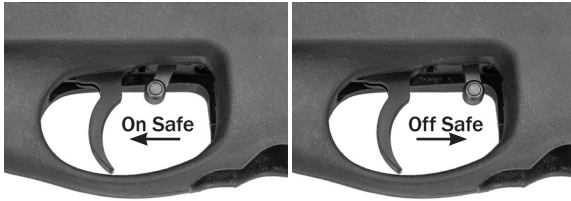

Fig. 1

Fig. 2

CAUTION: Until you are actually ready to shoot, keep the safety in the “ON” position (Fig. 1).

Section IV. ADJUSTABLE TRIGGER

Your air rifle is equipped with a 2-stage adjustable Quattro Trigger. The adjustments can be accessed through openings near the back of the stock. (Fig. 3)

For easier access, the stock can be disassembled by removing the stock connection screws by using a 5mm hex key tool. (Fig. 4) **NOTE:** Trigger adjustments are best tested with the stock attached to the rifle.



Fig. 3



Fig. 4

The Quattro Trigger is adjustable as seen in Fig. 5

SCREW#1 adjusts the amount of overlap or depth of engagement of the sear. For less trigger travel prior to discharge, rotate SCREW#1 clockwise; and vice versa.

SCREW#2 adjusts the transition from 1st to 2nd stage.

For a shorter 1st stage, rotate SCREW#2 clockwise; and vice versa.

SCREW#3 adjusts the trigger pull force. When this is turned clockwise, the force increases; and vice versa.

NOTE: Make only small changes to one adjuster at a time.

Over-adjusting can render the trigger inoperable and may create a dangerous situation! Take note of the starting point of each adjuster so that you can return it to its original position if necessary.

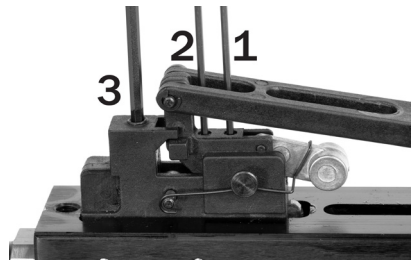

Fig. 5

Section V. COMFORT ADJUSTMENTS

Comb Adjustment: The comb is adjustable for elevation. Simply loosen the nut beneath comb and adjust the comb elevation suitable to your aiming position. (Fig. 6A & 6B)



Fig. 6A



Fig. 6B

Safety button can be set to ‘ON’ and ‘OFF’ position manually.

To set the safety to ‘ON’, pull safety lever to the rear. In this position, the trigger cannot be pulled and the gun cannot be fired. (Fig. 1)

To move the safety to ‘OFF’, push safety lever forward. In this position, the gun is ready to shoot. (Fig. 2)

Section VI. OPERATING INSTRUCTIONS

Warning!

Take all safety measures before filling the air cylinder. It is compulsory for the user and bystanders to wear eye & ear protection when filling the air cylinder.

Before filling the air cylinder; make sure the safety is in the ON position, no pellets are loaded in the air rifle and/or barrel. Fill air tube after cocking the gun and keeping the cocking handle/bolt open at the rear.

While filling the air cylinder; the pressure in the air cylinder must be monitored from the air gauge of the fill source. A pressure gauge must be incorporated into the filling equipment. Do not look at the air gauge on the air cylinder during filling process. Instead, reference the gauge on your fill device.

Charging the Rifle:

1. Pull the cocking handle backwards until it stops and locks at the back. This will open the fill safety gate. **(Fig.7A & 7B) THIS OPERATION COCKS THE TRIGGER MECHANISM/HAMMER ASSEMBLY. IF THE SAFETY IS SET TO OFF POSITION AND THE TRIGGER IS PULLED, THE RIFLE WILL DISCHARGE.**
2. Ensure both filler nozzle and rifle filler hole are clear from dirt and gently push the nozzle into the filler hole. **(Fig.7C)**
3. Fill the rifle to the cylinder pressure quoted previously in this manual. Do not exceed the maximum fill pressure as this may damage rifle components and may cause danger to you and others around you. When using diver's bottle, refill the rifle slowly to prevent heat created by the filling process from damaging the rifles components.
4. Undo the bleeder valve on the hose before disconnecting the fill nozzle from the rifle.

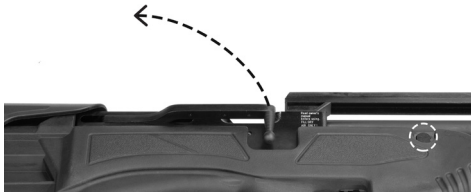

Fig. 7A



Fig. 7B

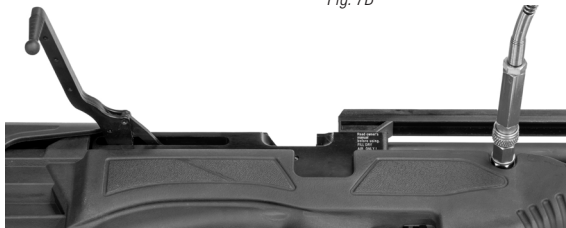

Fig. 7C

Loading the rifle & shooting:

1. Pull the cocking handle backwards until it stops.
THIS OPERATION COCKS THE TRIGGER MECHANISM/HAMMER ASSEMBLY. IF THE SAFETY IS SET TO OFF POSITION AND THE TRIGGER IS PULLED, THE RIFLE WILL DISCHARGE.
2. Load one round by placing it into the open channel. **(Fig 8A)**
DO NOT CLOSE THE COCKING HANDLE / MAGAZINE RELEASE BOLT UNTIL YOU ARE READY TO FIRE. ENSURE THE COCKING HANDLE IS FULLY CLOSED BEFORE FIRING THE RIFLE AS ITS PERFORMANCE WILL BE AFFECTED IF NOT FULLY CLOSED.
3. Close the cocking handle and ensure that it lays flat against the rifle **(Fig. 8B)**. Aim at your intended target and disengage the safety and prepare to shoot.

4. Pull the trigger gently and the rifle will fire.
5. To reload rifle, pull the cocking handle to its rear-most position. Then, repeat steps 2 through 6.



Fig. 8A



Fig. 8B

Section VII. MAINTENANCE

Warning!

Never attempt to disassemble this rifle when it is charged, except for removal and replacement of the air cylinder. Never fire the rifle when the air cylinder is removed or empty. Failure to obey this instruction could result in damage to your rifle.

Never lubricate inside the barrel as this will affect the accuracy & grouping of the rifle in negative manner.

- Occasionally apply proper mineral based oils sparingly to the following parts:
- The trigger mechanism
- The pellet probe
- The cocking lever sliding surfaces

DO NOT OVER-LUBRICATE THE RIFLE!

- It is recommended to clean the barrel with a cleaning rod every 500-1000 shots. Never lubricate inside the barrel.
- Before you begin oiling or cleaning your air gun, always check to make sure it is unloaded.
- Always be sure your gun barrel is clean and not blocked.
- After cleaning ensure that no cleaning patch or other obstruction remains in the barrel.
- Annually, take your air gun to a gunsmith even if it seems to be working well, since some issues in your gun may not be apparent from external examination.
- Take your air gun to a gunsmith if water, sand, etc. enters the internal mechanism of the air gun, for complete cleaning.
- Dangerous conditions may occur if you do not keep your air gun clean and working properly.

Quick Fill Nozzle O-Rings Replacement

After a period of time, the O-rings on the fill nozzle will need to be replaced. The need for this will become noticeable if air is heard leaking from the nozzle or the nozzle is ejected from the port while charging the rifle. Always ensure to replace both O-rings.

Loading Probe O-rings Replacement

The O-ring which seals the loading probe against the barrel will need to be replaced after many hundreds of shots have been fired. Its replacement becomes apparent when the rifle's cocking lever becomes stiff to operate or if air is released from the breech when firing. Lightly oil the replacement O-ring before fitting.

Safety Measures & Warnings

- This air gun will fire if cocked, loaded, safety disengaged and trigger pulled.
- Air guns are not toys. Never let young children use an air gun unsupervised. Adult supervision is strictly required during use. Misuse or careless use may cause serious injury or death.
- This is a high-powered airgun for use by those 16 years of age or older.
- Learn how your air gun operates and practice safe gun handling procedures before loading and using it.
- **ALWAYS USE EYE & HEARING PROTECTION AND MAKE BYSTANDERS USE THE SAME.** Failure to do so may result in eye injuries and permanent hearing loss.
- Do not point at anything you do not intend to shoot even though the gun is unloaded. Always keep the gun pointed in a safe direction.
- Never pull a gun toward you by the muzzle.
- Always aim at a safe target, taking care that it does not conceal any other object.
- Before you fire, consider where the pellet will travel should you miss your intended target, thus ensuring no damage or harm could result.
- Be sure of your target before you pull the trigger. Never shoot at sounds.
- When shooting, always have a safe shooting range, that is; have a safe area for shooting, a safe distance between you and the target, and a safe backstop to trap the pellets and hold the target.
- Do not fire at a target, which allows ricochets or deflections. Do not fire into or at water.
- Do not fire at or near power lines or insulators. Be especially careful in wooded areas where power lines may not be as visible.
- Do not load the gun until you are ready to shoot.
- Always keep your fingers away from the trigger & muzzle during cocking and handling.
- Do not walk, run or jump when carrying a loaded or cocked air gun. A loaded or a cocked gun should never be carried inside a vehicle, house, camp or public place. Never climb a tree or fence or jump a ditch with a loaded gun. In such a case, first unload it and hand the gun to a friend or place it on the ground on the other side of the obstacle before crossing yourself.
- When transporting the gun, keep it unloaded and 'on safe'.
- Always keep the gun 'on safe' until you are ready to shoot even if the gun is unloaded.
- Do not put the gun away loaded and unattended.
- Always check to see if the gun is 'on safe' and unloaded when getting it from another person or from storage.
- Always keep the air gun and/or pellets out of the reach of children. Keep the air gun and pellets in separate places, better if under lock and key.
- Do not attempt to disassemble or tamper with your gun. Use a competent gunsmith. Many air guns contain powerful springs or high pressure air cylinders which can cause serious injury if released in an uncontrolled manner.
- Always handle and treat your gun as though it were loaded.
- Improper use or handling of air guns is not the responsibility of the manufacturer or distributor, under any circumstances. The user is responsible for any harm, which may be caused.
- Think first, fire second. Don't rely on any mechanical safety. Half safe is not safe.
- Be safe not sorry. Respect other's property.
- Air guns should never be used under the influences of alcohol or drugs.
- Do not brandish or display this product in public – it could confuse people and may be a crime.
- Do not change the coloration and markings to make it look more like a firearm.



Serious. Solid. Impact.

HATSAN

ARMS COMPANY

Kemalpasa O.S.B. Mah. Ansizca Sanayi Sitesi No: 303 Ic Kapi No: 1, 35170

Kemalpasa - Izmir - TURKEY

Tel: +90 (232) 878 91 00 • Fax: +90 (232) 878 91 02

www.hatsan.com.tr info@hatsan.com.tr