

# BENJAMIN®

## EXPLODED VIEW & PARTS LIST

### MARAUDER .22 Caliber Pre-Charged Pneumatic Air pistol MODEL BP2220



Manufacture Start Date: 11/1/10

Last Update: 8/26/14

CROSMAN CORPORATION  
7629 ROUTES 5 & 20  
BLOOMFIELD, NY 14469  
Phone: 1-800-724-7486  
Parts Order Fax: 585-657-5405

[www.crosman.com](http://www.crosman.com)

- This EVP and parts list is intended to be an informational guide in ordering parts. It is not instructional material and we therefore assume no responsibility for those who use the same without proper factory training.
- Please order by part number and description.
- Check or money order for the total price must accompany the order.
- For current prices contact Crosman Corporation at 1-800-724-7486 or visit our website [www.crosman.com](http://www.crosman.com)

**PARTS LIST FOR MODEL BP2220**

Manufacture Start Date: 11/1/10

	PART NUMBER	DESCRIPTION	Qty.
1	2220-102	Assy, Bolt, .22 Cal	1
2	1700-018	Stud, Bolt	1
3	2220-004	Breech	1
4	1700-008	Screw, 4-40 X 1.125, SHCS	4
5	1763-023	Set Screw, 8-32 x.250, Flat PT	4
6	68AT-035	O-Ring	1
7	190B-008	O-Ring 3/8 X 1/2	1
8	2220-011	Mount, Shroud	1
9	88-089	Screw, Set	1
10	1761A023	O-Ring, #2-009	1
11	2220-017	Barrel, .22 Cal, 12"	1
12	2220-009	Shroud, Barrel	1
13	130-035	O-Ring, Seal .630 .424 .103	2
14	2220-010	Cap, Shroud	1
15	2220-012	Spacer, Barrel	1
16	1700-019	Plate, Bolt Indexing	1
17	1700-020	Screw, 3-48 X .188, PPH	2
18	2220-014	Sleeve, Transfer Port	1
19	130-036	Seal, Face .260 .165 .085	2
20	1763A036	Striker	1
21	CH2009-023	Pin, Acetal	1
22	1700-015	Hammer Pin	1
23	CH2009A009	Hammer	1
24	1700-009	Spring, Hammer	1
25	1700-011	Guide, Hammer Spring	1
26	1700-012	Cap, Tube	1
27	2220-029	Grip, Left	1
28	1700-029	Screw, 8-32 X .312, SHCS	1
<b>29</b>	<b>2220-103</b>	<b>Assy, Grip Frame (See pg.4)</b>	<b>1</b>
30	2220-007	Bracket, Mounting	1
31	2220-005	Screw, 8-32 X .437, SHCS	1
32	2220-030	Grip, Right	1
33	105-054	Screw, 6-32, Mach Oval .5	2
34	2220-002	Forestock	1
35	2220-003	Screw, 8-32 X .375, BHCS	2
<b>36</b>	<b>1761-102</b>	<b>Fill Cap Assembly (See pg.6)</b>	<b>1</b>
<b>37</b>	<b>1700-101</b>	<b>Fill Adapter Assy. (See pg.5)</b>	<b>1</b>
<b>38</b>	<b>1700-104</b>	<b>Gauge Port Assembly (See pg.6)</b>	<b>1</b>
39	2220-031	Spacer	1
<b>40</b>	<b>1700-100</b>	<b>Valve Assembly (See pg.5)</b>	<b>1</b>

	PART NUMBER	DESCRIPTION	Qty.
41	2220-008	Barrel Band	1
42	2220-001	Tube, Reservoir	1
43	1700-010	Screw, 8-32x .188, SHCS, Low Head	3
44	1763-033	Gauge, Pressure	1

ASSEMBLY NUMBERS

29	TRIGGER ASSEMBLY (Page 4)
36	FILL CAP ASSEMBLY (Page 6)
37	FILL ADAPTER ASSEMBLY (Page 5)
38	GAUGE PORT ASSEMBLY (Page 6)
40	VALVE ASSEMBLY (Page 5)

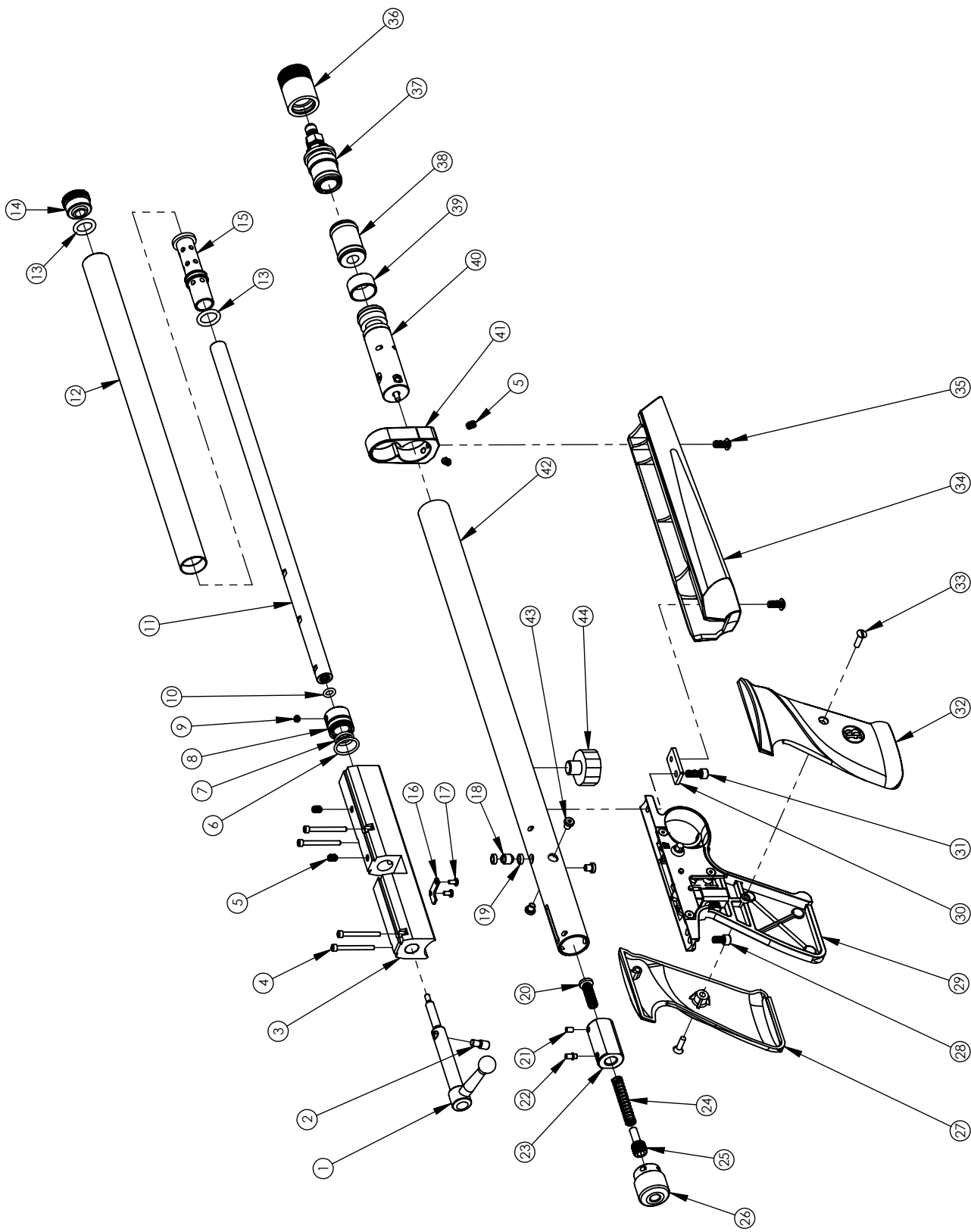

**BENJAMIN MODEL BP2220 MARAUDER .22 CALIBER PISTOL**

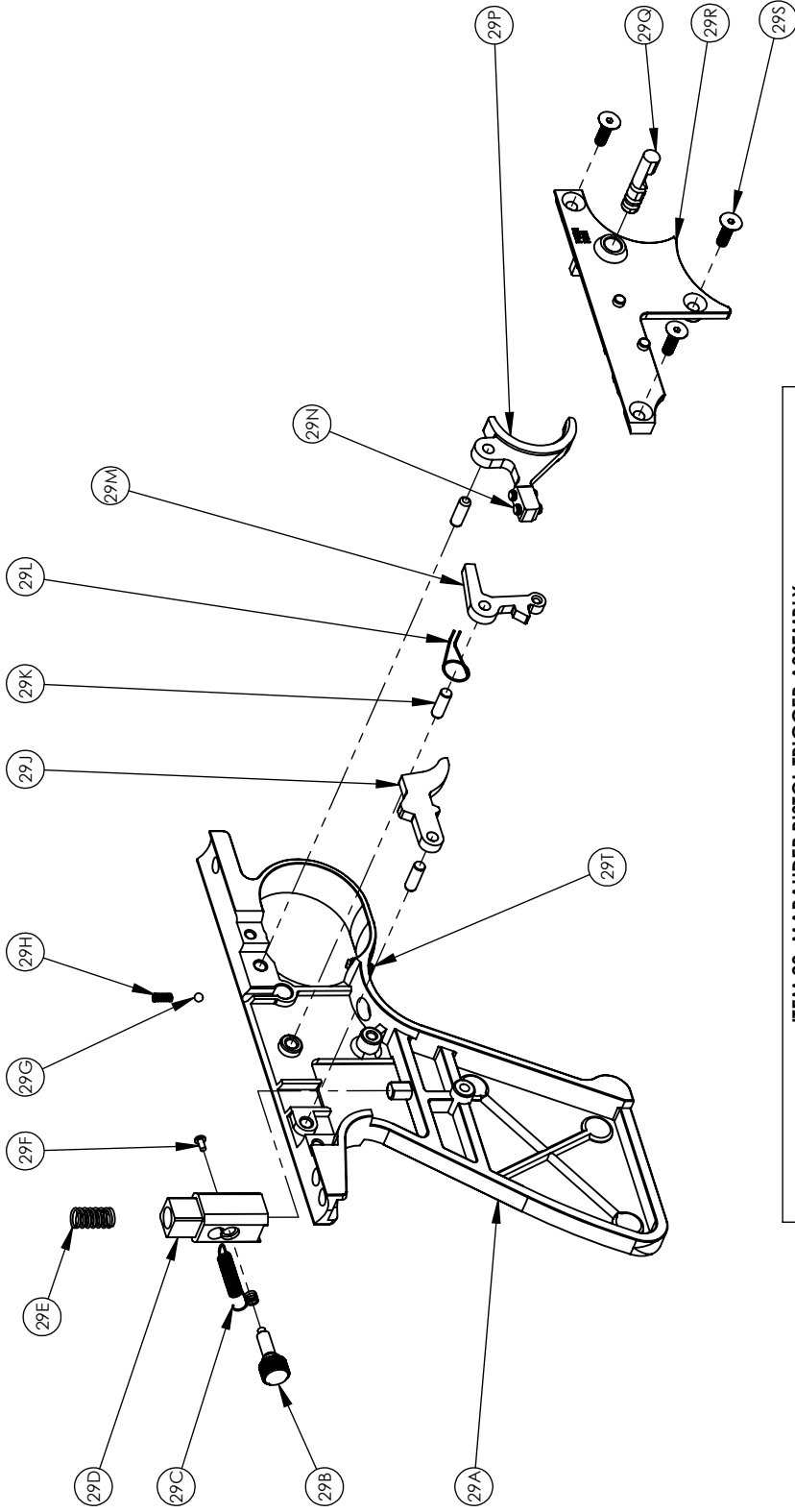

ITEM 29, MARAUDER PISTOL TRIGGER ASSEMBLY			
ITEM NO.	PART NUMBER	DESCRIPTION	QTY.
29A	2220-018	FRAME, TRIGGER	1
29B	2220-013	SCREW, ADJUSTER	1
29C	2220-022	SPRING, LINK	1
29D	2220-015	HOUSING, ADJUSTER	1
29E	2220-024	SPRING, SEAR	1
29F	2220-026	SCREW, 0-80 x .125, PPH	1
29G	105-039	DIA .093 STEEL BALL	1
29H	1322-017	SPRING, SAFETY	1
29J	2220-021	SEAR	1
29K	2220-025	PIN, DOWEL, .125 X .375	3
29L	2220-023	SPRING, TRIGGER	1
29M	2220-020	LINK, TRIGGER	1
29N	17 63-055	SET SCREW, 4-40 x .312, OV PT	2
29P	2220-019	TRIGGER	1
29Q	1322-052	SAFETY	1
29R	1322B044	COVER	1
29S	17 63-056	SCREW, 4-40 x .375, FHCS	3
29T	2300-042	SETSCREW 8-32 x .25 BRASS TIP	1

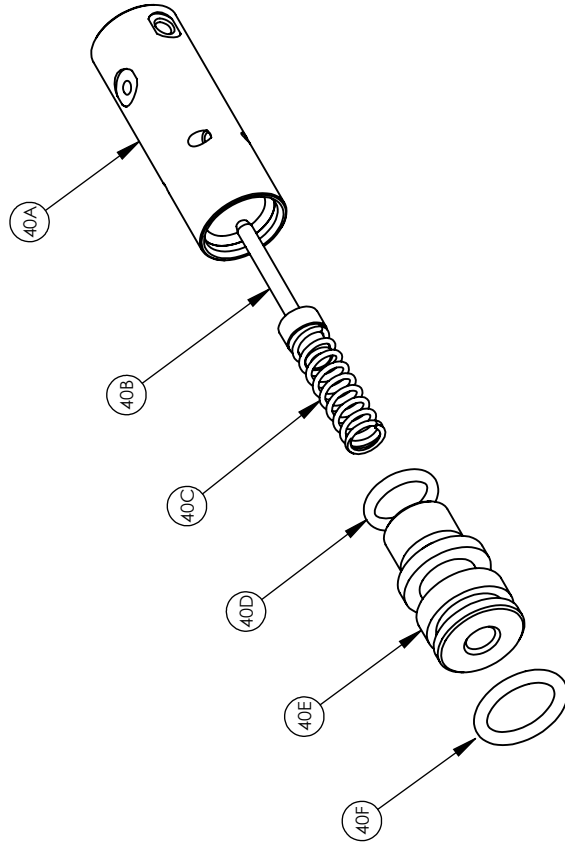

ITEM 40, VALVE ASSEMBLY			
ITEM NO.	PART NUMBER	DESCRIPTION	QTY.
40A	1700-002	VALVE BODY	1
40B	1700-140	VALVE STEM, OVERMOLDED	1
40C	1763-034	SPRING, VALVE	1
40D	130-035	O-RING	1
40E	1700-003	VALVE CAP	1
40F	1700B005	O-RING, AS568B -113, 80 D	1

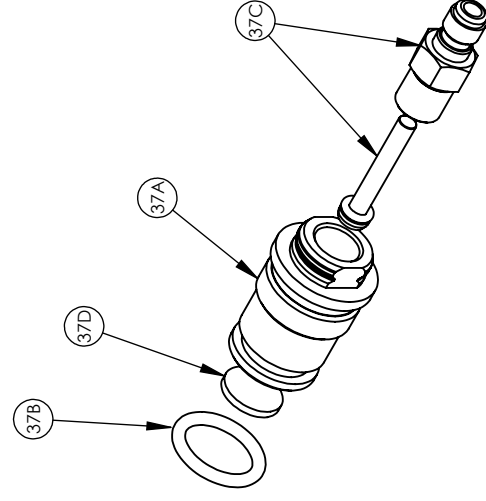

ITEM 37, FILL ADAPTER ASSEMBLY			
ITEM NO.	PART NUMBER	DESCRIPTION	QTY.
37A	1700-013	HOUSING, FILL ADAPTER	1
37B	1700B005	O-RING, AS568B -113, 80 D	1
37C	1761-106	NIPPLE, ADAPTER	1
37D	NS1200-047	SINTERED FILTER	1

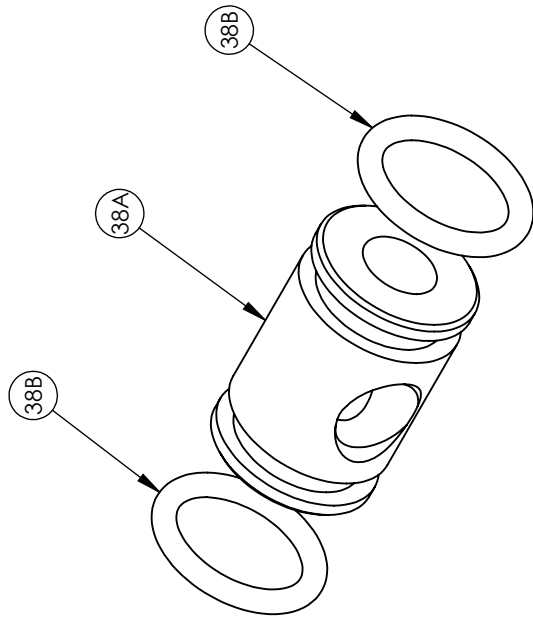

ITEM 38, GAUGE PORT ASSEMBLY			
ITEM NO.	PART NUMBER	DESCRIPTION	QTY.
38A	1700-016	PORT, GAUGE	1
38B	1700B005	O-RING, AS568B -113, 80 D	2

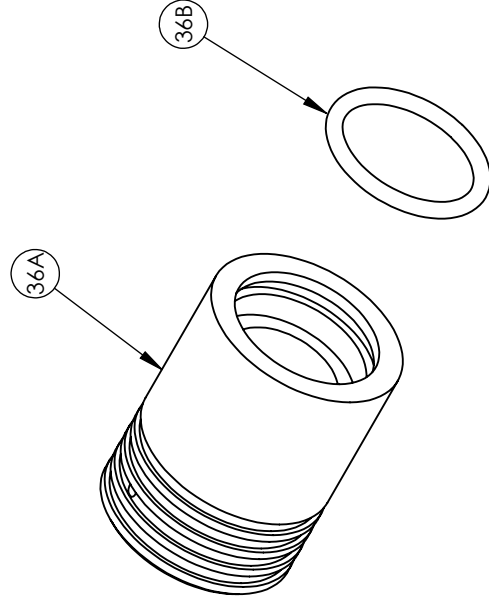

ITEM 36, FILL CAP ASSEMBLY			
ITEM NO.	PART NUMBER	DESCRIPTION	QTY.
36A	1761-011	CAP, ADAPTER	1
36B	1761-005	O-RING, AS568-016	1